

THREE QUARTER RAIL CONVERSION KIT INSTALLATION

For Benno® Boost, 46er, and RemiDemi XL (with High Rail or High Rail Plus)

READ CAREFULLY BEFORE INSTALLATION AND USAGE. TO BE INSTALLED BY MECHANIC AT AUTHORIZED BENNO DEALER.

HIGHRAIL / HIGH RAIL PLUS
SETUP REQUIRED

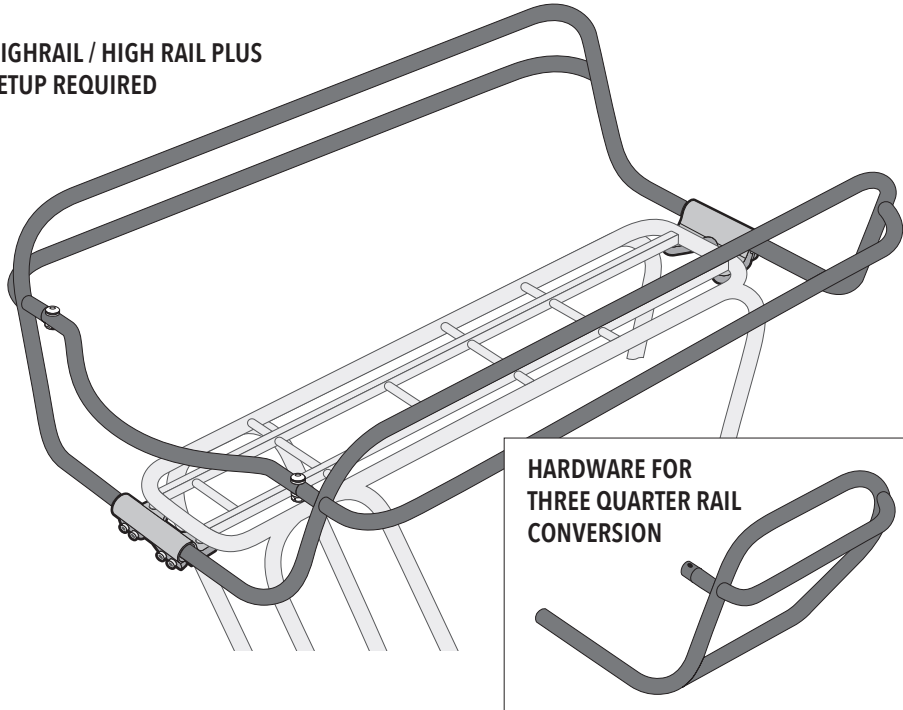

IMPORTANT: *Notes to mechanic:* See Instructions. Install Benno three quarter rail conversion kit only on compatible Benno high rails or high rail plus and use only pre-drilled holes and fittings. Do not mount to damaged clamps, racks or rails. Do not modify clamps, racks or rails, change position or drill new holes as this will void any warranties and/or claims for liability.

Notes to owner: Periodically check to make sure all nuts and bolts remain tightened as vibrations may loosen them. Ensure that all needed passenger accessories remain on the bike while carrying passengers. See WARNING! on back for more information.

CONVERTING HIGHRAIL TO THREE QUARTER RAIL

1. Unscrew the **M6** bolt and remove it, along with the spacers and nut, as shown (set these components aside for future use). Loosen all 8 bolts on the front and rear clamp. Gently pull out the right rail (**A**) from the clamps, as well as the rear rail (**B**).

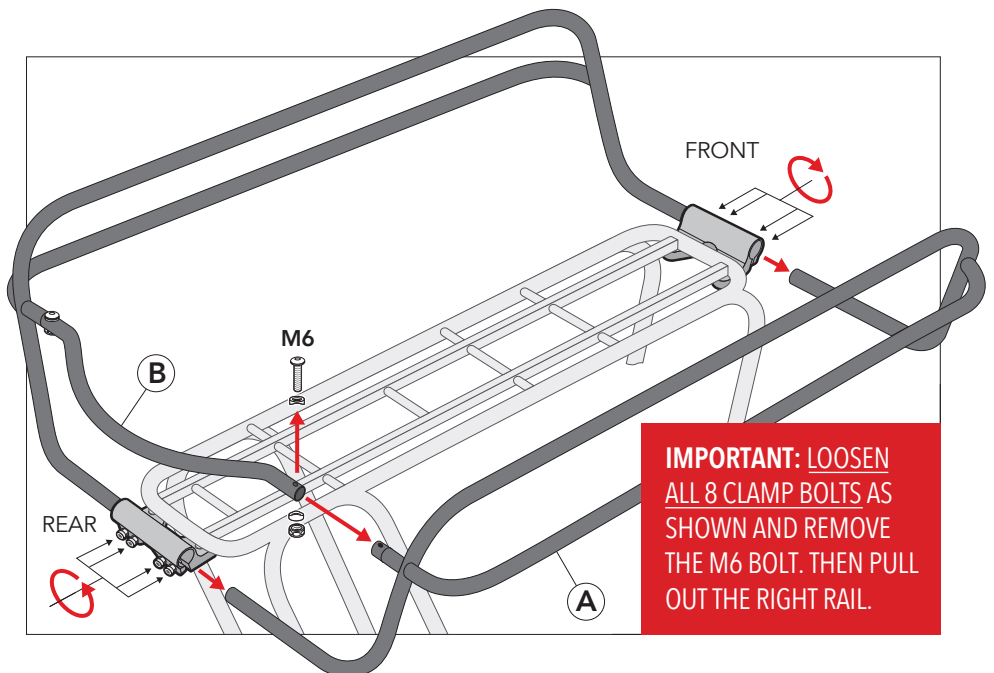

COMPATIBILITY

BOOST

46ER

REMIDEMI XL

IMPORTANT: LOOSEN ALL 8 CLAMP BOLTS AS SHOWN AND REMOVE THE M6 BOLT. THEN PULL OUT THE RIGHT RAIL.

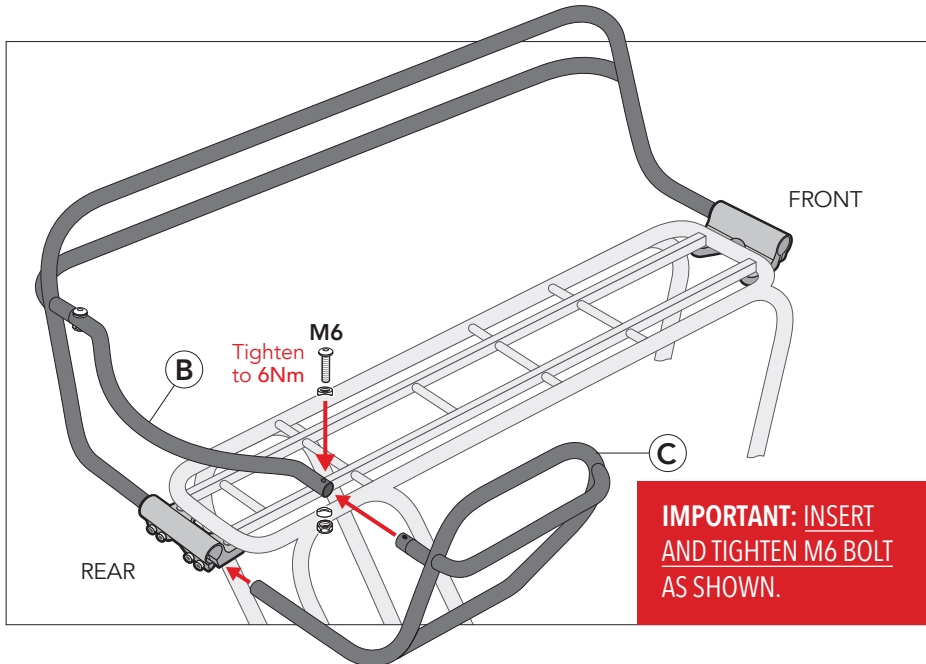

2. Insert lower end of three quarter rail (C) from the right side into the rear clamp until it comes to a stop while connecting the upper end to the rear rail (B) as shown. Insert and tighten M6 bolt, spacers and nut as shown to ensure secure connection between rail (B) and three quarter rail (C).

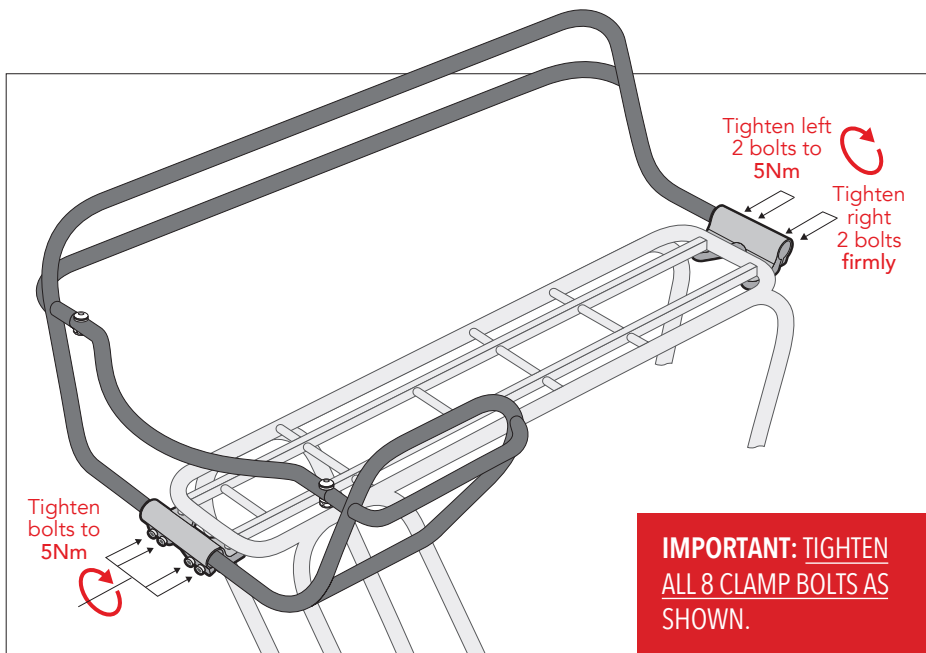

3. Now tighten all 8 bolts on the rail clamps (front and rear) as shown. Please double-check all nuts and bolts.

* Benno bike model specific pannier bags with full rear wheel coverage. See bennobikes.com for compatibility information.

WARNING!

REAR WHEEL MUST BE COVERED!
INSTALL PASSENGER ACCESSORIES BEFORE CARRYING PASSENGERS!
FAILURE TO DO SO COULD RESULT IN SERIOUS INJURY!



MUST INSTALL
 -RAIL or PASSENGER BAR
 -RACK PADS
 -WHEEL GUARDS or designated PANNIER BAGS*
 -SIDELOADER

WHEN CARRYING PASSENGERS, REAR WHEEL MUST BE COVERED! INSTALL BENNO WHEEL GUARDS OR DESIGNATED BENNO PANNIER BAGS*, RAIL OR PASSENGER BAR, RACK PADS AND SIDELOADER. FAILURE TO DO SO COULD RESULT IN SERIOUS INJURY! MAKE SURE THAT NO PARTS OF THE BODY OR CLOTHING COME NEAR MOVING PARTS ON THE BICYCLE, SUCH AS CHAIN, SPOKES, TIRES OR BRAKES. PASSENGERS MUST BE ABLE TO SECURELY HOLD THEMSELVES ON THE BIKE. DO NOT EXCEED TOTAL MAX GROSS WEIGHT OF THE BIKE AND/OR RACK MAX LOAD. BENNO RAILS MAY HELP STABILIZE LOAD DURING NORMAL OPERATION BUT DO NOT PROTECT IN THE EVENT OF AN ACCIDENT OR BIKE FALLING OVER. RAILS DO NOT INCREASE MAX LOAD INDICATED ON RACK. DO NOT SIT OR STAND ON RAILS.

