

46ER THREE QUARTER RAIL INSTALLATION

For Benno® 46er

READ CAREFULLY BEFORE INSTALLATION AND USAGE. TO BE INSTALLED BY MECHANIC AT AUTHORIZED BENNO DEALER.



IMPORTANT: MUST BE INSTALLED WITH RAIL CLAMPS PLUS. (NOT INCLUDED. MUST BE PURCHASED SEPARATELY)

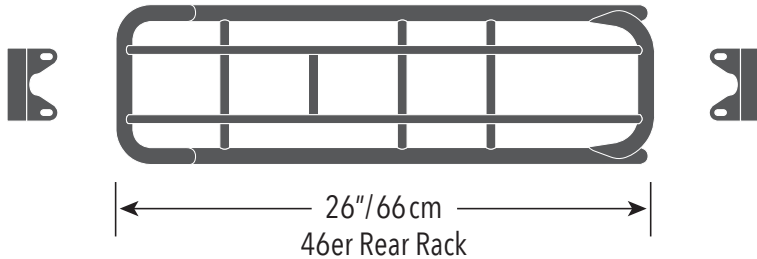

IMPORTANT: *Notes to mechanic:* See diagram. Install Benno rail clamps and rails only on compatible Benno rear racks and use only pre-drilled holes and fittings. Do not mount clamps and rails to damaged racks. Use only original Benno rails with the Benno rail clamps. Do not modify clamps, racks or rails, change position or drill new holes as this will void any warranties and/or claims for liability.

Notes to owner: Periodically check to make sure all nuts and bolts remain tightened as vibrations may loosen them. Ensure that all needed passenger accessories remain on the bike while carrying passengers. See **WARNING!** on back for more information.

STEP 1: RAIL CLAMP PLUS INSTALLATION

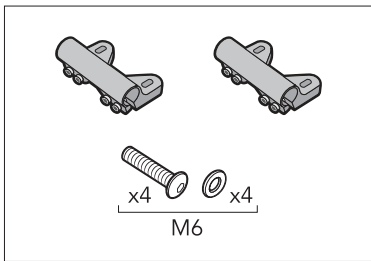

1. Ensure correct hardware count before installation. Included are two clamps and four M6 bolts and washers.

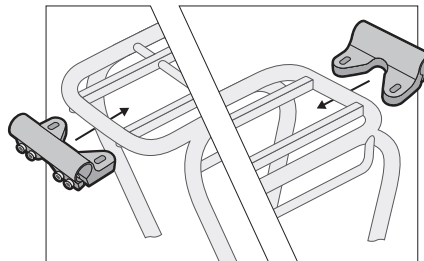

2. Place one clamp on each end of the rack (front and rear). Insert clamps from below and line up with the two fittings on the underside of the rack.

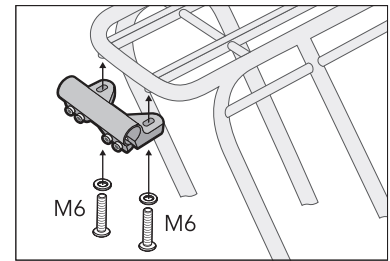

3. Insert the two M6 bolts through the slotted holes of the clamp and screw into the fittings on the underside of the rack. **HAND-TIGHTEN BOLTS SLIGHTLY – CLAMPS STILL NEED TO BE ABLE TO MOVE.**

STEP 2: THREE QUARTER RAIL INSTALLATION

4. Insert both lower ends of left rail (A) from the left side all the way into the center of the clamps until they come to a stop. Loosen clamp bolts as needed for easy insertion. **DO NOT TIGHTEN YET.** Then connect rear rail (B) to the upper end of the left rail (A) as shown. Use M6 bolt, spacers and nut as shown to ensure connection between rail (A) and rail (B).

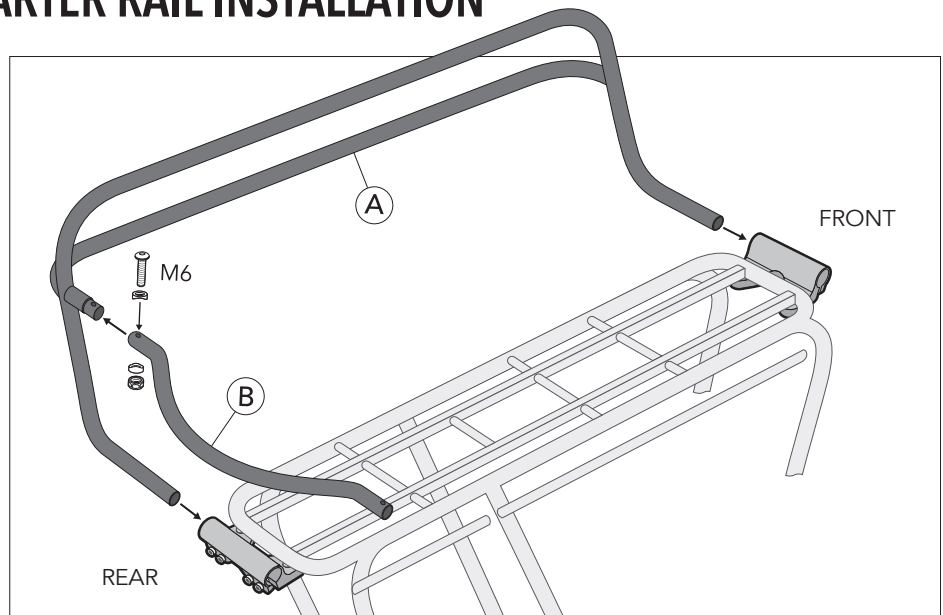

COMPATIBILITY

46ER

FOR 46er **EVOLUTION FINDER GO TO:**
BENNOBIKES.COM/46er/EVOLUTION

EVO (evolution) replaces model years and refers to design generations.

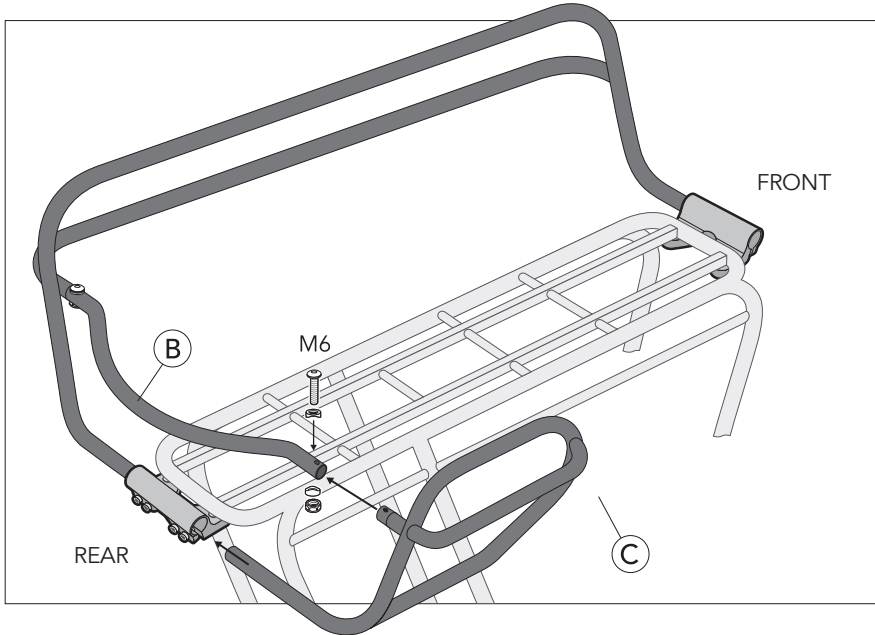

5. Insert lower end of right rail (C) from the right side into the center of the clamp until it comes to a stop while connecting the upper end to the rear rail (B) as shown. Use M6 bolt, spacers and nut as shown to ensure secure connection between rail (B) and rail (C).

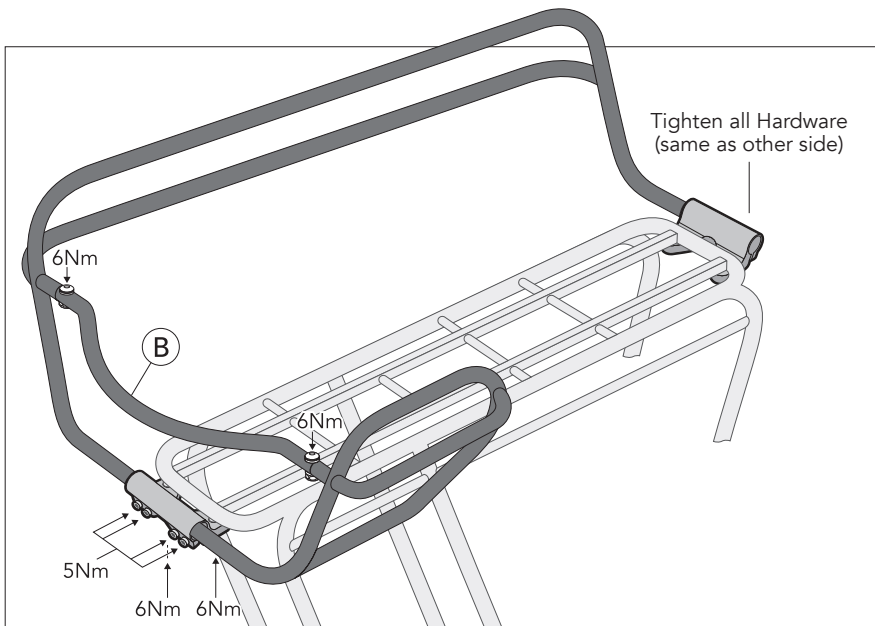

6. Once all pieces are installed, adjust and straighten rails and clamps as needed.

IMPORTANT:
NOW TIGHTEN ALL HARDWARE FIRMLY
 (see Nm in illustration).
 Please double-check all 14 nuts and bolts.

WARNING!
REAR WHEEL MUST BE COVERED!
INSTALL PASSENGER ACCESSORIES
BEFORE CARRYING PASSENGERS!
FAILURE TO DO SO COULD
RESULT IN SERIOUS INJURY!



MUST INSTALL
 -RAIL or PASSENGER BAR
 -RACK PADS
 -WHEEL GUARDS or
 UTILITY PANNIER BAGS
 -SIDELoader

WHEN CARRYING PASSENGERS, REAR WHEEL MUST BE COVERED! INSTALL BENNO WHEEL GUARDS OR UTILITY PANNIER BAGS, RAIL OR PASSENGER BAR, RACK PADS AND SIDELoader. FAILURE TO DO SO COULD RESULT IN SERIOUS INJURY! MAKE SURE THAT NO PARTS OF THE BODY OR CLOTHING COME NEAR MOVING PARTS ON THE BICYCLE, SUCH AS CHAIN, SPOKES, TIRES OR BRAKES. PASSENGERS MUST BE ABLE TO SECURELY HOLD THEMSELVES ON THE BIKE. DO NOT EXCEED TOTAL MAX GROSS WEIGHT OF THE BIKE AND/OR RACK MAX LOAD. BENNO RAILS MAY HELP STABILIZE LOAD DURING NORMAL OPERATION BUT DO NOT PROTECT IN THE EVENT OF AN ACCIDENT OR BIKE FALLING OVER. RAILS DO NOT INCREASE MAX LOAD INDICATED ON RACK. DO NOT SIT OR STAND ON RAILS.